

PIN2 (UART Rx) i PIN4 (UART Tx)  
służą do aktualizacji oprogramowania

53mm x 21mm x 7mm

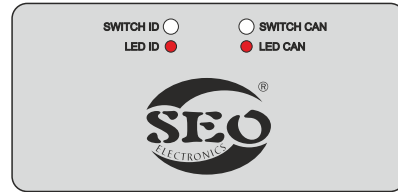

PCB U322

60mm x 30mm x 6mm

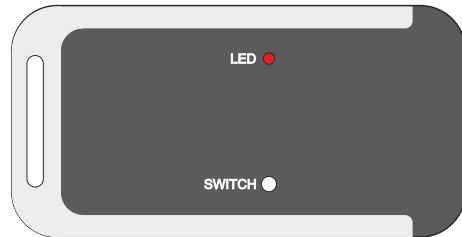

ID Transmitter (01xxxxxx)  
PCB U370

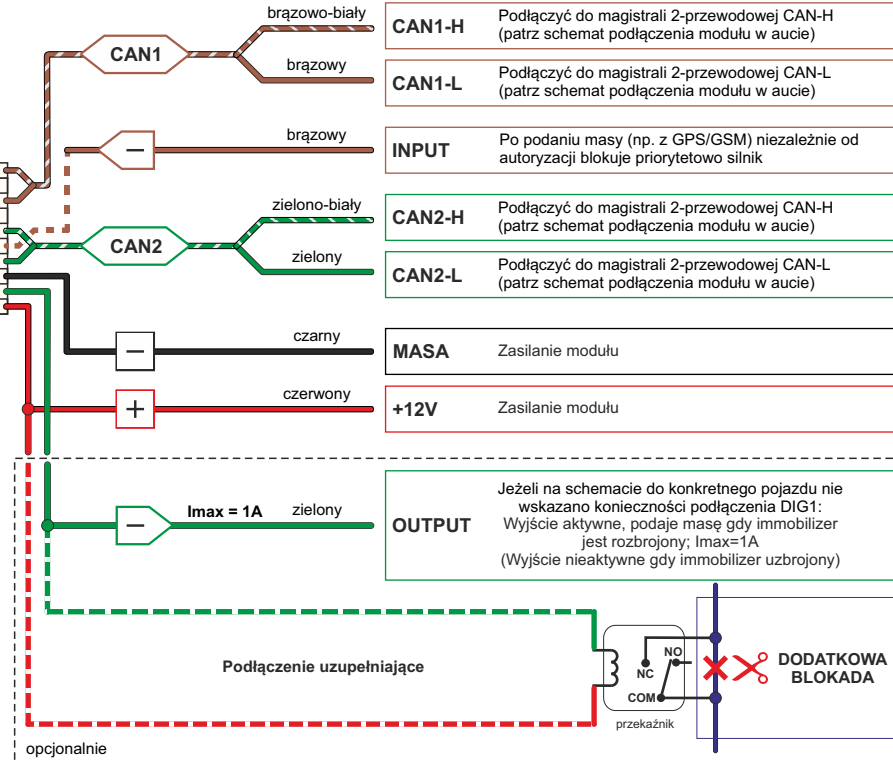

LUB

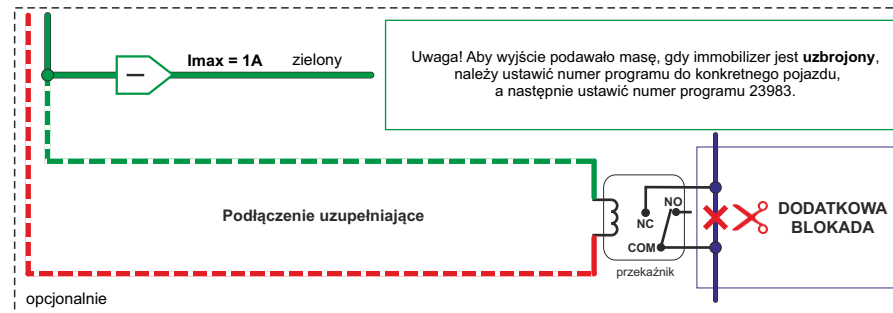

PIN2 (UART Rx) i PIN4 (UART Tx)  
służą do aktualizacji oprogramowania

53mm x 21mm x 7mm

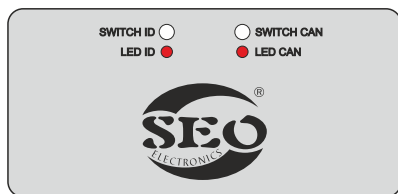

PCB U322

60mm x 30mm x 6mm

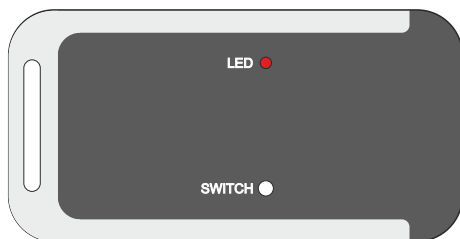

ID Transmitter (01xxxxxx)  
PCB U370

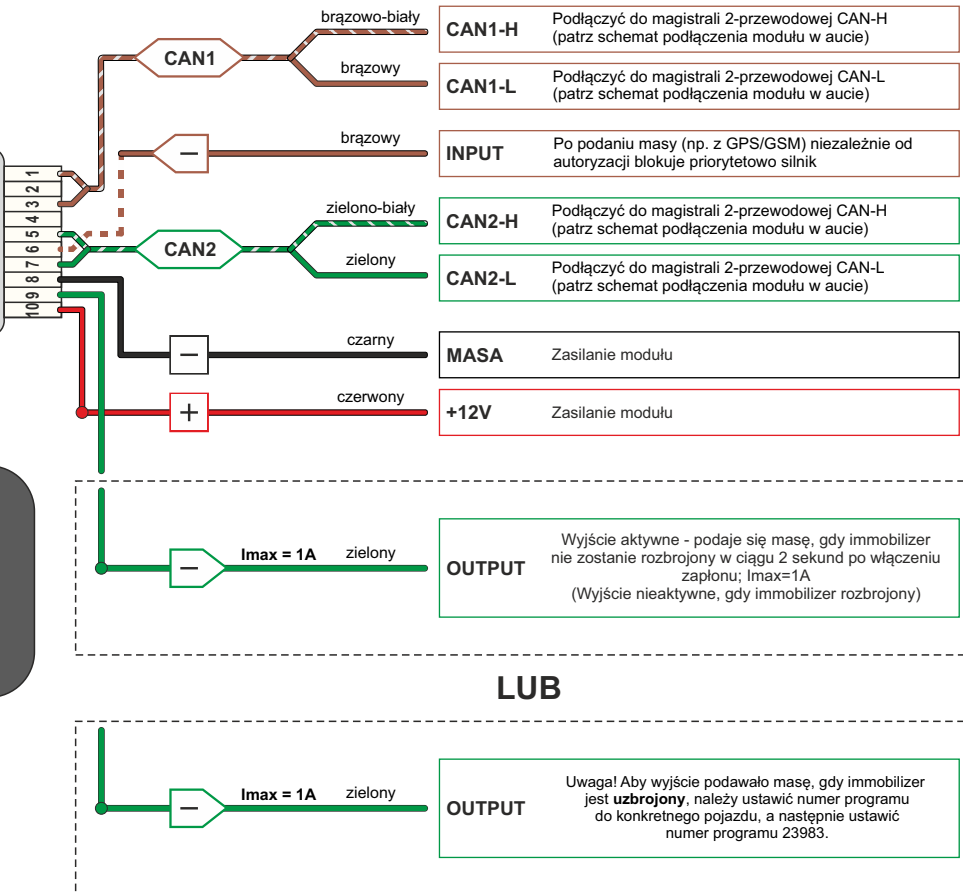

Marka i typ: **SEO CANblu**

Wersja: **276111xx**

rok: **18** →

rev01